



## Three Roll Mill

Practical and well dispersed!

# TRL SERIES

## Lab Three Roll Mill

Application: Mainly used for ointment, lubricant grease, cosmetics, CNT, metal paste, new ceramic material, electronics paste, solar paste etc...

### Feature

- Variable speed to mix, refine, disperse, or homogenize viscous materials fed into it.
- Spring-tensioning scraper holder is more precise and effective for discharge. Scraper/Knife tightness can be adjusted.
- Final fineness can be reached to 1-20 microns.
- Compact design saves space and lighter for transport.
- PLC system with touch panel is available for digital and smart control.
- Roller gap to lum.
- Ceramic or Chrome hardened rollers.

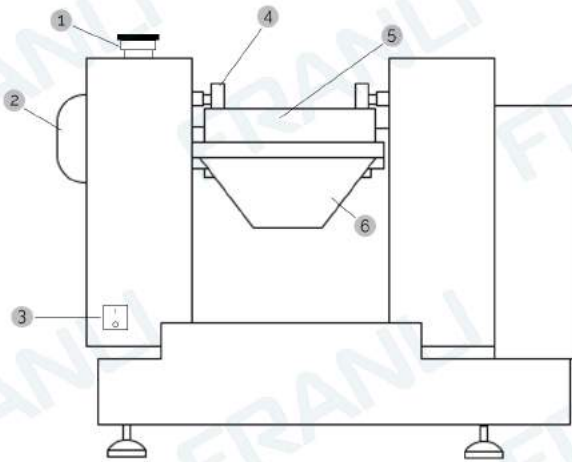

### Equipment details

- 1 Emergency stop button
- 2 Speed control box
- 3 Switch
- 4 Baffle
- 5 Roller
- 6 Scraper knife

Type	Data
Roller dia (mm)	50
Working length(mm)	150
Capacity(L/H)	0.02-10
Speed Ratio	4:2:1
Speed(rpm)	580
Main motor power(kw)	0.15-0.2
Weight(kg)	20
Size(mm)	350x250x300

## Equipment details

- ① Ceramic roll
- ② Scraper knife
- ③ Teflon baffle
- ④ Emergency stop button
- ⑤ Operation desk
- ⑥ Schneider electrical component



Type	Data
Roller dia (mm)	80
Working length(mm)	200
Capacity(L/H)	0.02-20
Speed Ratio	9:3:1
Speed(rpm)	480
Main motor power(kw)	1.1
Weight(kg)	80
Size(mm)	350x250x300





# Your Best Chemical Production Line Manufacturer in China



FRANLI MACHINERY CO.,LTD

Tel:+86 15306118977

E-mail:Judy@franli.com

Add:Maker Space-5,Science &  
Education Town,No.18Changwu  
Middle Road, China

**FRANLI**®

[www.franli.com](http://www.franli.com)